



SERVICE INSTRUCTION SK-SI005 Rev A Page 1 of 7

EFFECTIVE DATE: This Service Instruction is effective **October 19, 2020.**

COMPLIANCE TIME: *This retrofit installation is optional and not required. Compliance with this service instruction is at the discretion of the owner/operator.*

SUBJECT: *INSTALLATION OF AFT SEAT*

MODELS AFFECTED: *CCK-1865 & CCK-2000*

PURPOSE: *To replace existing sling seat with a solid aft seat.*

PARTS LIST:

<u>PART</u>	<u>DESCRIPTION</u>	<u>QTY</u>
AN320-3	NUT, PLAIN, CASTELLATED, SHEAR	2
AN3-5	BOLT, MACHINE, AIRCRAFT	2
AN3-5A	BOLT, MACHINE, AIRCRAFT	4
AN363-524	NUT, HI-TEMP LOCK	2
AN364-1032A	NUT, NYLON LOCK	8
AN380-2-2	COTTER PIN	2
AN5-20A	BOLT, MACHINE, AIRCRAFT	2
AN960-10L	WASHER, FLAT, THIN	20
AN960-416	WASHER, FLAT	2
AN960-416L	WASHER, FLAT, THIN	2
AN960-516L	WASHER, FLAT, THIN	4
C80012-17	BUSHING, ELEVATOR UPPER LINK	2
MS21250-04010	BOLT, TENSION, STEEL, EXTERNAL WRENCHING	2
MS24694-S52	SCREW, COUNTERSUNK	4
SC29102-001	SEAT ADJUSTMENT DOUBLER	2
SC29103-001	SEAT BASE - AFT ATTACH BRACKET	1
SC29103-002	SEAT BASE - AFT ATTACH BRACKET	1
SC29106-001	CAM BUSHING	2
SC29110-001	SEAT BASE - FORWARD WELDMENT	1



SERVICE INSTRUCTION SK-SI005 Rev A Page 2 of 7

SC29120-001	AFT SEAT BEAM - AFT BEAM WELDMENT	1
SC29130-001	REAR SEAT CROSS TUBE ASSEMBLY	1
SC29140-001	SEAT ASSEMBLY, STANDARD	1
SC29140-003	SEAT ASSEMBLY, SCS LEATHER	OPT

Note: This Service Instruction does not include seat belt harnesses, or cross tube tie downs, which are common to both the sling and solid rear seats. Please contact CubCrafters if you need these parts.

INSTRUCTIONS:

1. Read all instructions before beginning any work.

Note: Installation requires match drilling parts inside cabin.

2. Remove the existing sling seat, lower aft seat belt harnesses, and rear seat cross tube.
3. Install aft seat beam (SC29120-001) across the top of the seat belt harness tabs on the floor, as shown below. Hardware needs to only be snug, as the beam will require removal before final installation.

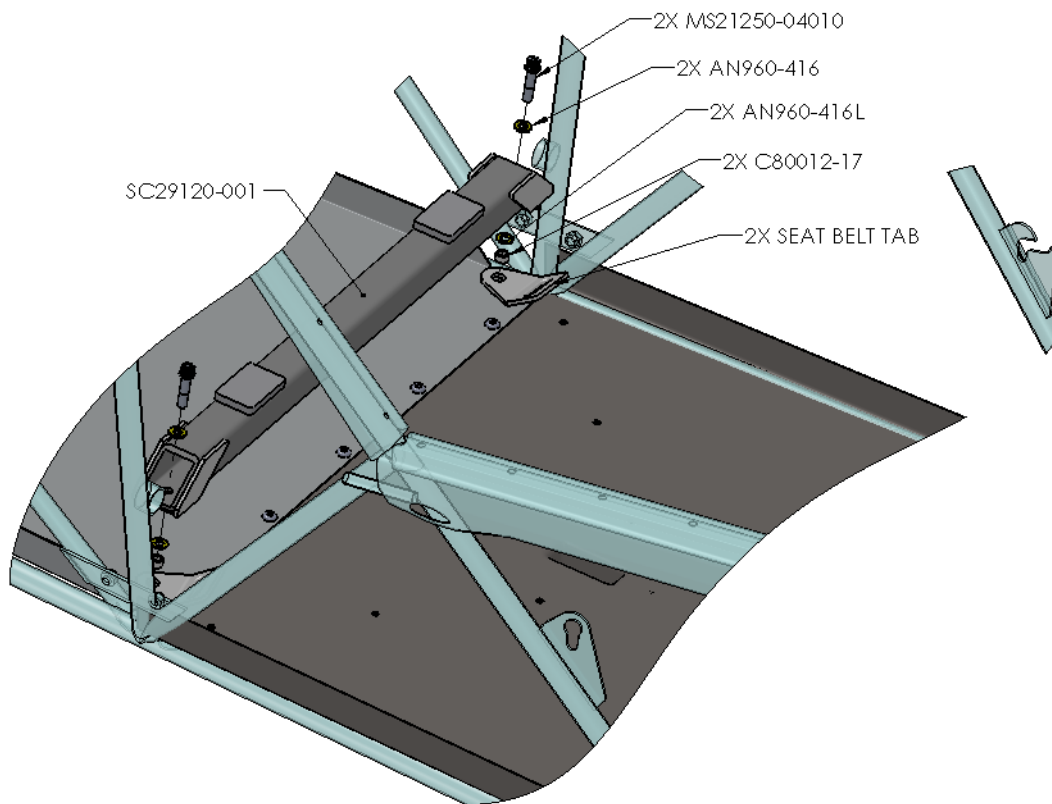

Figure 1 – Aft Seat Beam Temporary Installation

- Prep the seat base (SC29110-001) by installing the adjustment doublers (qty 2: SC29102-001) as shown below. Torque nuts to 30 inlbs.

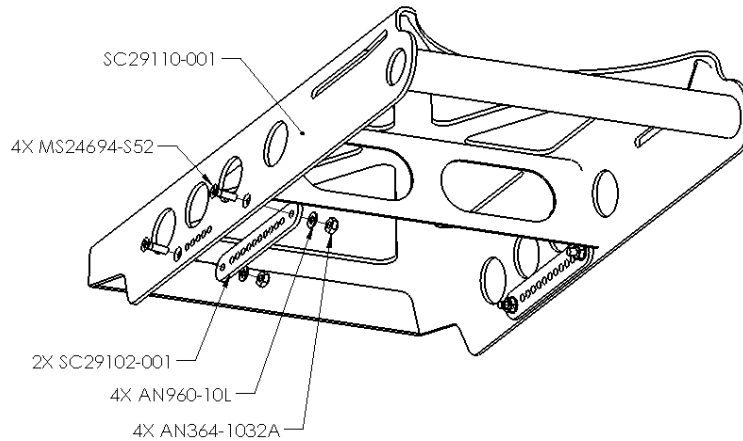

Figure 2 – Adjustment Doubler Installation

- Slide the Rear Seat Cross Tube (SC29130-001) through the front tube of the Seat Base Weldment (SC29110-001) and install in fuselage as shown in Figure 3. Let the aft end of the seat base rest on the pads of the aft seat beam (SC29120-001).

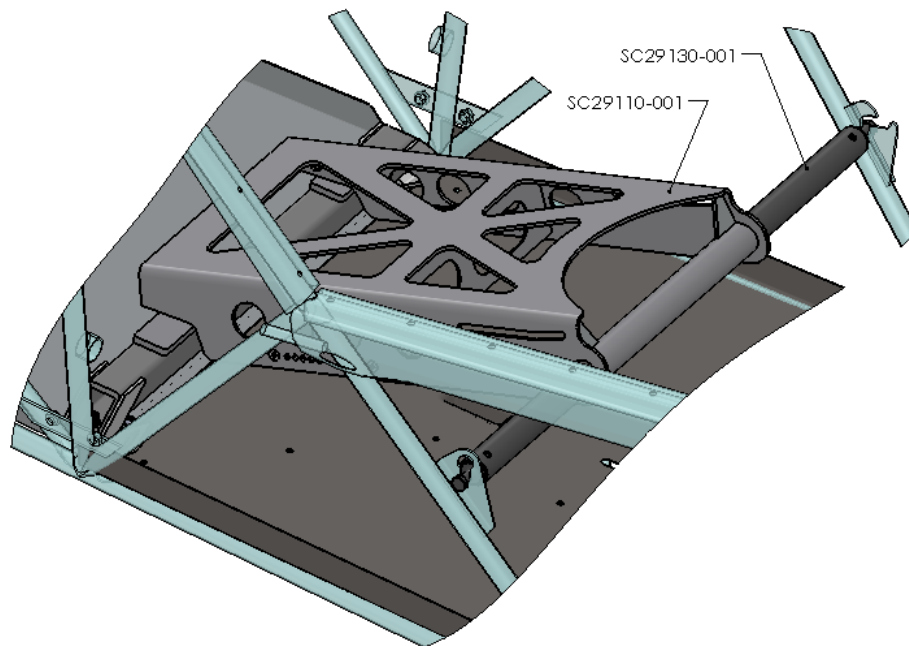

Figure 3 – Seat Base Positioning

- Locate the SC29103-001/-002 brackets. If they do not already have pilot holes, measure and drill $\varnothing.188$ and $\varnothing.302$ holes as shown in Figure 4.

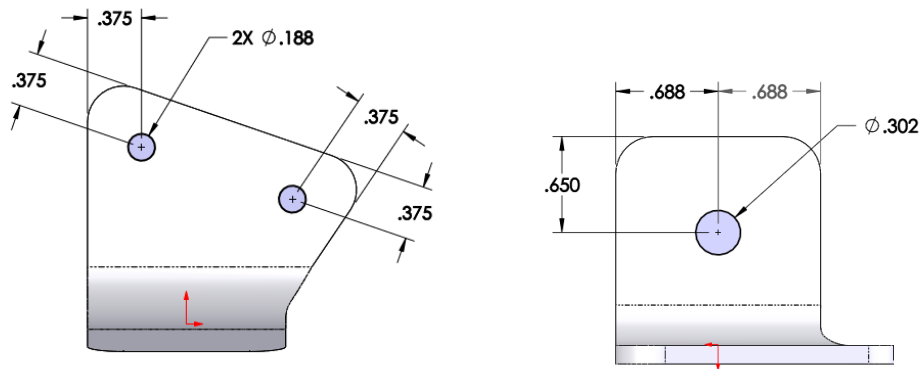

Figure 4 – Bracket Prep (SC29103-001/-002)

- Set the attach brackets (SC29103-001/-002) on the beam (SC29120-001) and up against the seat base (SC29110-001), as shown in Figure 5. The -001 part goes on the aircraft left side, and the -002 goes on the aircraft right. The seat base should be centered left and right in the fuselage, and the brackets should be centered fore and aft on the pads of the aft seat beam. The brackets should rest on the pads of the beam, but to avoid contact between the base (SC29110-001) and the beam (SC29120-001), place a shim under the seat base so there's a gap of 1/32"-1/16" between the aft edge of the pads of the aft seat beam and the seat base. With parts in place, either mark the hole locations of the brackets to the seat base, or clamp the brackets to the seat base.

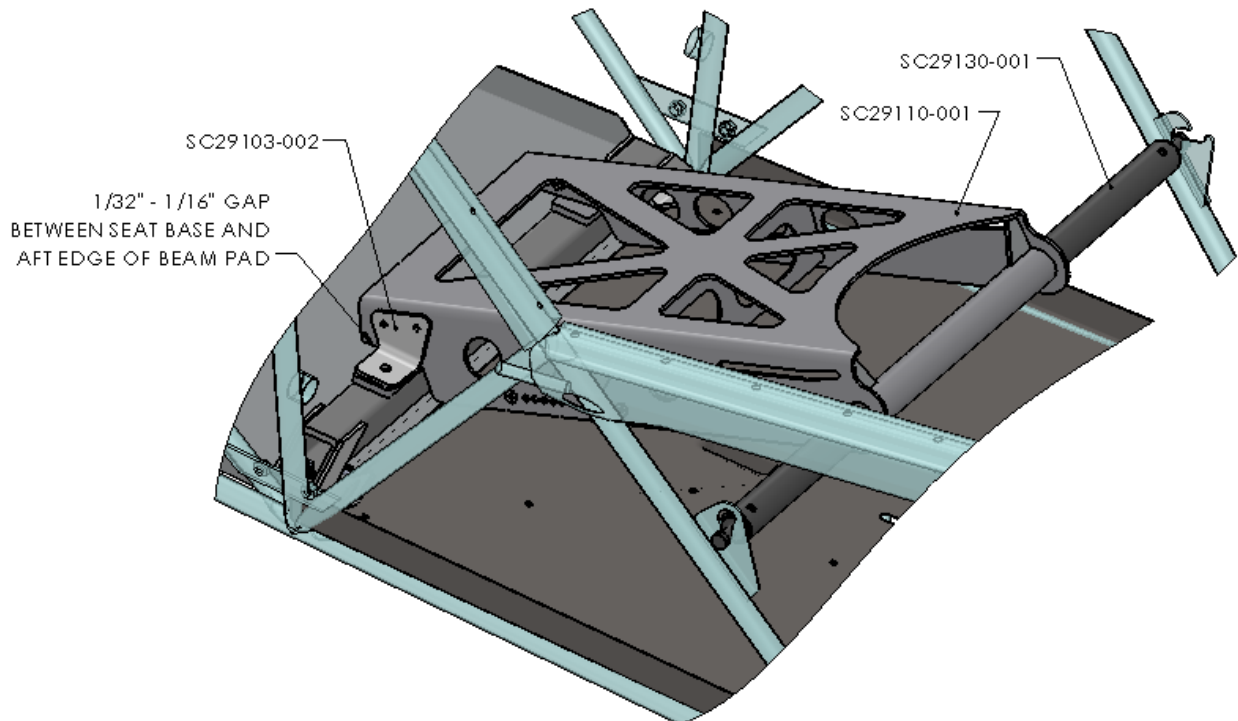

Figure 5 – Seat Base Match Drilling

8. Remove the seat base and match drill $\text{\O}.$ 201 holes in the brackets and base (through the $\text{\O}.$ 188 holes in the brackets) .
9. Install the brackets onto the seat base with AN3-5A bolts, AN960-10L washers, and AN364-1032A nuts. Torque nuts to 38 inlbs.
10. Reinstall the seat base and center left and right. The brackets that were just bolted to the seat base should sit flush on the pads of the beam and the holes in the brackets should be centered on the beam fore-and-aft.
11. Match drill a $\text{\O}.$ 316 hole down through one of the brackets and the beam. The hole will go all the way through the beam. To ensure no damage is done to the floorboard, or underlying fuselage tubes, place a piece of scrap metal under the beam before drilling. This process will produce a lot of aluminum chips, so a blanket under the beam may also be used to avoid FOD in the fuselage. Once one of the holes is drilled, drop a 5/16 bolt or pin in the hole to ensure the seat base doesn't move; repeat the match drilling process for the second bracket.
12. Remove the seat base and beam.
13. Bolt the beam to the seat base using AN5-20A bolts, AN960-516L washers, and AN363-524 nuts. Torque nuts to 100in-lbs. Be careful tightening nuts, as over-torqueing will crush the beam.

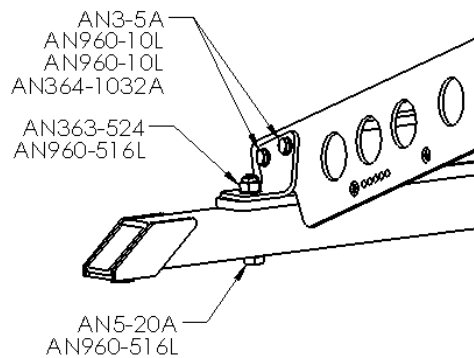

Figure 6 – Bracket Hardware

14. Bolt the seat assembly to the seat base as shown below.

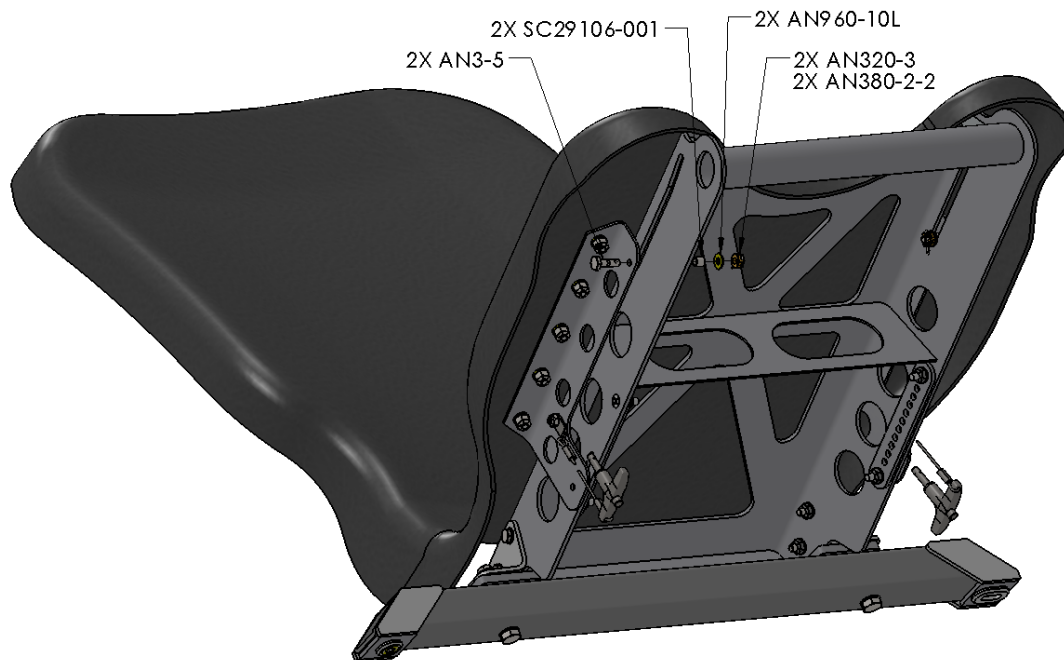

Figure 7 – Seat Assembly

15. Weigh the entire seat assembly and record the weight (typically around 17lbs). Update the aircraft weight and balance accordingly.
16. Reinstall the entire seat subassembly into the fuselage. Bolt the cross beam to the fuselage using hardware shown in Figure 1.
17. Cinch down the rear seat cross tube (SC29130-001) at the front of the seat with rear seat tie downs (SC22850).
18. Make a logbook entry stating the aft seat has been installed in accordance with SK-SI005 Rev NC.

If you are no longer in possession of this aircraft, please forward this information to the present owner/operator and notify Cub Crafters, Inc. Contact the customer service department at:

Cub Crafters, Inc.
 1918 S. 16th Avenue
 Yakima, WA 98903
 1-877-484-7865 or 1-509-248-9491
support@cubcrafters.com

Please include the aircraft registration number, serial number, current name, and address of the owner and/or operator.