



SERVICE BULLETIN

SB00029

Rev C

Page 1 of 22

Cub Crafters, Inc. Considers Compliance Mandatory

This Service Bulletin meets requirements of ASTM F2295-06.

It is a Safety Directive for the purpose of compliance with 14 CFR 91.327(b)(4).

EFFECTIVE DATE: This Service Bulletin is effective September 22, 2014.

SUBJECT: *ADDITIONAL FUEL LINE DRAIN*

MODELS AFFECTED: *CC11-100 AND CC11-160 S/N 0001 THROUGH S/N 00263*

COMPLIANCE TIME: **PART A:** *BEFORE NEXT FLIGHT*
PART B: *DUE WITHIN 100 HOURS OR AT NEXT ANNUAL CONDITION INSPECTION, WHICHEVER OCCURS FIRST*

CONTINUED INSPECTION: *AT NEXT ANNUAL CONDITION INSPECTION, OR WHEN THE AIRCRAFT HAS BEEN PARKED IN THE FOLLOWING CONDITIONS (UNTIL PART B OF THIS SERVICE BULLETIN HAS BEEN COMPLIED WITH):*

- *CONDITIONS WHERE CONDENSATION MAY HAVE ACCUMULATED IN THE FUEL SYSTEM*
- *HEAVY OR PROLONGED PRECIPITATION*
- *WHENEVER THERE IS ANY QUESTION THAT WATER MAY HAVE ACCUMULATED IN THE FUEL SYSTEM*

PURPOSE: While there have been no reports of incident, Cub Crafters, Inc. has determined that there is potential for a low spot to form in the left aft fuel line where condensation could collect. This service bulletin provides instructions for retrofitting aircraft to include an additional fuel drain to avoid the potential of water collecting in the line.

PARTS LIST:

<u>PART</u>	<u>DESCRIPTION</u>	<u>QTY</u>
AN365-632A	NUT, NYLON LOCK	2
AN526C632R5	SCREW, 6-32 X 5/16 SS	4
AN526C632R6	TRUSS HEAD SCREW, 6-32 X 3/8 SS	2
DJSB00029-001	FUEL DRAIN DRILL JIG STICKER	1
HDW-261-765	NYLON INSERT	8
HDW-A1785-6Z-1	#6 TINNEMAN NUT	6
HDW-S6R.375TA	SHEET METAL SCREW, #6 THREAD	6
HDW-SR-5065B	NYLON SNAP RIVET, BLACK	10
MS35489-11	RUBBER GROMMET	1
MS35489-12	RUBBER GROMMET	1



Cub Crafters, Inc. Considers Compliance Mandatory

RM0005-001	GROMMET STRIP	16"
RM0012-101	3M ADHESIVE PROMOTOR	1 BTL
RM1004-022	ROUNDIT PROTECTIVE WRAP, ½"	6'
RM1015-008	.50" LOOP TAPE, ADHESIVE	49"
RM1016-008	.50" HOOK TAPE, ADHESIVE	49"
RM1075-002	CABLE TIES, 5.8" HEAT STABILIZED	20
RM4905-002	3M ACRYLIC DOUBLESIDED TAPE	4'
RM5595-003	NYLON TUBING, .50 OD X .380 ID	9"
SC53107-001	BOOT COWL HATCH	1
SC60102-001	COMPRESSION NUT	1
SC60103-001	COMPRESSION INSERT	1
SC60110-001	FORWARD FUEL DRAIN WELDMENT	1
SP60002-001	DRAIN ASSEMBLY	1
SP60003-001	NYLON UNION TEE	2
SP60004-001	NYLON UNION ELBOW	1
SP60009-003	NYLON TUBING, .375 OD X .250 ID	5'
TC9350-042	FUEL DRAIN PLACARD	3
AVAILABLE LOCALLY		
RM0568-010	LOCTITE SUPER GLUE	AR
RM1070-001	3M ¾" FRICTION TAPE, BLACK	AR
RM6032-001	FUEL SYSTEM LUBRICANT, E-Z TURN	AR
RM0013-002	SILICONE, RTV HIGH TEMP RED	AR
VP13003-01	SILICONE SEALANT, CLEAR	AR

Cub Crafters, Inc. Considers Compliance Mandatory

PART A INSTRUCTIONS:

PRE-FLIGHT

1. Gently rock the wings of the aircraft by pushing on either the wing strut or wing tip by the front and rear spars.
2. Drain at least 16 fl oz. of fuel from the drain on the lower right side and the fuel gascolator on the forward left side. If water is present in the fuel, drain at least 16 fl oz. of fuel past the point when water was last observed.
3. Jack the tail of the aircraft to near flight level attitude (Ref. SC10000AMM or SSC10000AMM 6.3.2).
4. Repeat Step 2.

PART B INSTRUCTIONS:

1. Read all instructions and appendices before beginning any work.
2. Place a protective cover (carpet etc.) over the fabric of both sides of the landing gear.
3. If equipped, remove rear seat bar and stow rear sling seat per the Pilot's Operating Handbook (POH).
4. Drain all fuel from system (Ref. AMM 6.3.15.1).
5. Check the left interior panel on your aircraft to determine if it is secured to the window frame using hook and loop tape (Velcro™) or double-sided tape. If hook and loop tape, skip to step 8 below and skip steps 63-65 later. Skip step 8 if you have double-sided tape.
6. Install masking tape on fuselage below the panel seam as shown in Figure 1.
7. From outside the aircraft, run a putty knife between top lip of the panel and the fuselage along the length of the panel to break the bond of the double stick tape.
8. Open top of left interior panel by slipping a piece of sheet metal strap (approximately 2" wider than the hook and loop tape width and about 2" shorter than the hook and loop tape length) in one end and keep pushing it in, unlocking the hook and loop tape (see Figure 2 below). Tape in place so hook and loop tape stays unlocked while completing the rest of this service bulletin.



FIGURE 1 - Tape Installation on Fuselage

Cub Crafters, Inc. Considers Compliance Mandatory



FIGURE 2 – Metal Strap Placement

9. Remove fuel selector handle, gate, and fuel selector panel from the left interior panel.
10. Remove the pulley cover on the left side of the floor near the center of the interior panel.
11. Remove nylon snap rivets along the bottom edge, including some of the rivets in the aft interior panel.
12. Remove nylon snap rivets along vertical seam between left center interior panel and left aft interior panel.

CAUTION

Use extreme care in handling interior panels as they can crack easily and sharp corners may damage fabric covering on the aircraft.

Cub Crafters, Inc. Considers Compliance Mandatory

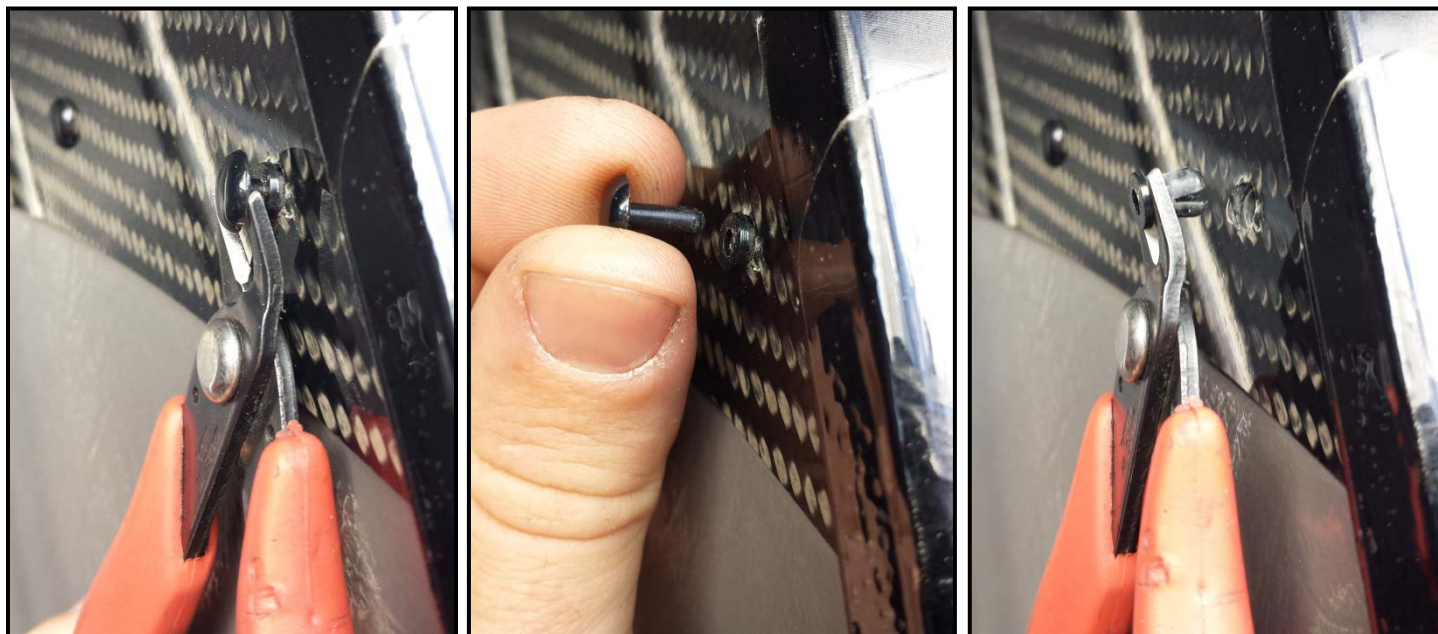

FIGURE 3 - Removal of Nylon Snap Rivet

NOTE

On removal, nylon snap rivets may break. Extra rivets are included in the kit.

13. Remove double stick tape along joint of forward and aft LH interior panels.
14. Ensure front of panel will clear any hardware. **Tape panel, if necessary, to protect finish.** Push panel inboard to expose fuel line routing.
15. Figure 4A shows forward section of fuel line routing as previously installed. Older aircraft may have an alternate fuel line routing, as shown in Figure 4B.

Cub Crafters, Inc. Considers Compliance Mandatory

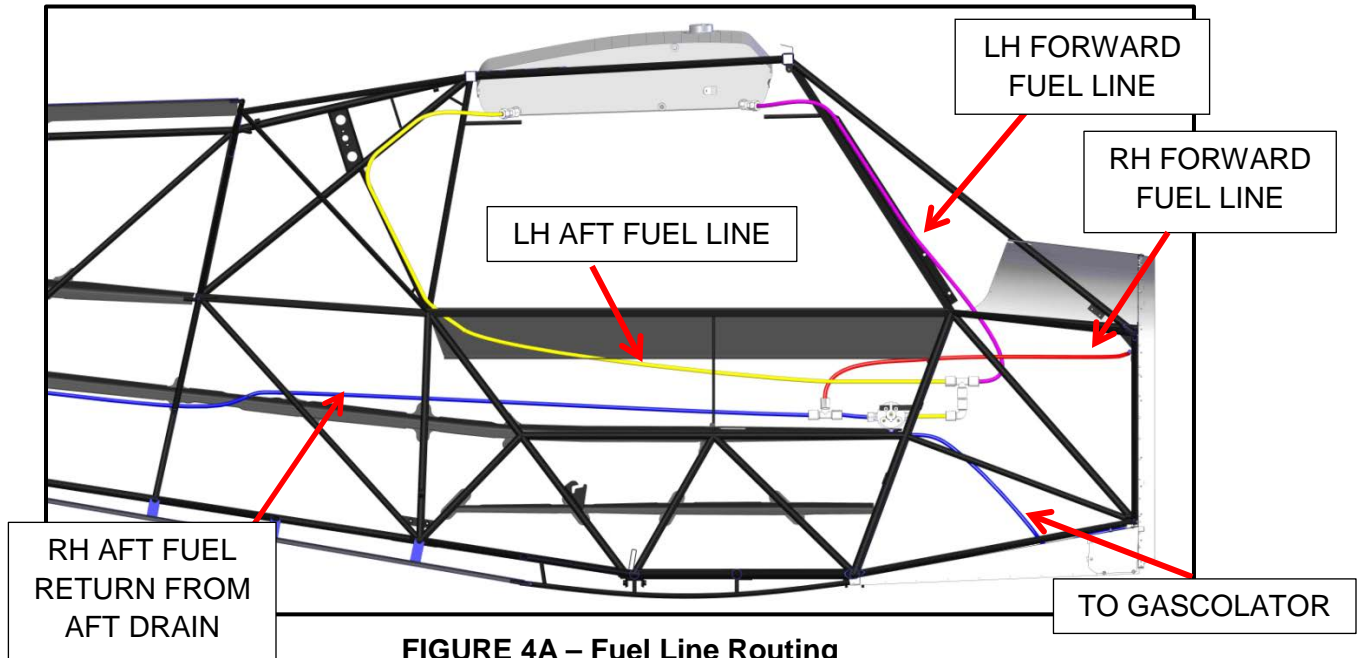

FIGURE 4A – Fuel Line Routing
(Note all modified fuel lines on the LH side of aircraft)

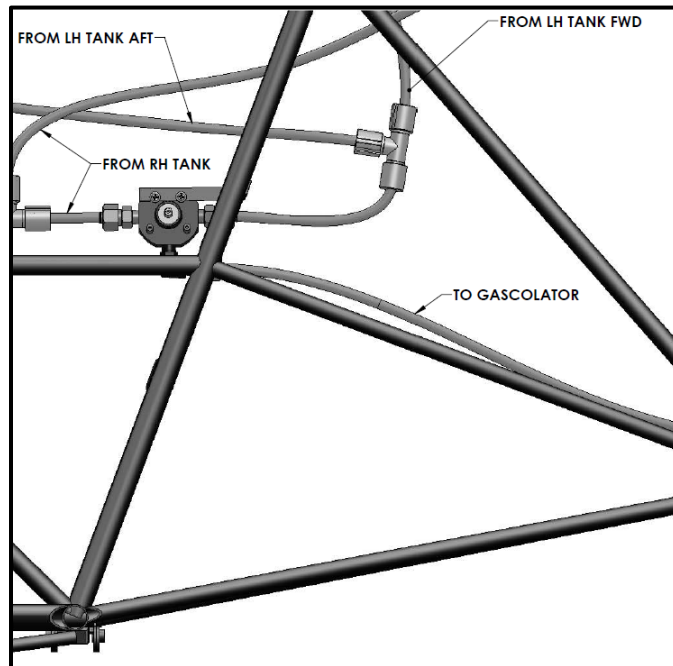

FIGURE 4B – Alternate Fuel Line Routing

Cub Crafters, Inc. Considers Compliance Mandatory

16. Disconnect throttle cable from throttle assembly (Ref. AMM 6.3.11).
17. Carefully remove panel from aircraft and set aside. It may be necessary to disconnect LH rudder cable from rudder pedals in order to gain sufficient clearance at lower aft corner of front interior panel section where it wraps around rudder cable fairlead.
18. Temporarily secure fuel selector body to mount tab on fuselage using original screws to maintain dimensions and clearances.
19. Remove the tee, elbow (if applicable) and short sections of fuel line forward of the fuel selector by cutting the tube where it joins the tee using a scissor type razor tubing cutter (see Figure 5A and 5B), then loosening the compression fitting at the forward connection of the fuel selector. The fuel lines may have residual fuel in the lines. Collect any fuel in a fuel safe container.
20. Remove any cable ties affixing the LH aft fuel line to the fuselage frame below or forward of lower rear window corner, then gently pull it out of the grommet where it passes through the boot cowl spacer. The grommet may be removed and discarded.

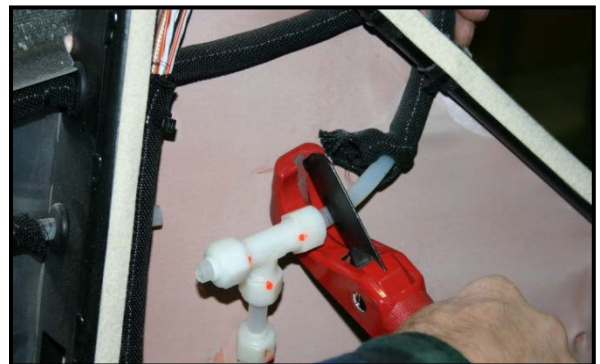

FIGURE 5A – Tubing Cutter

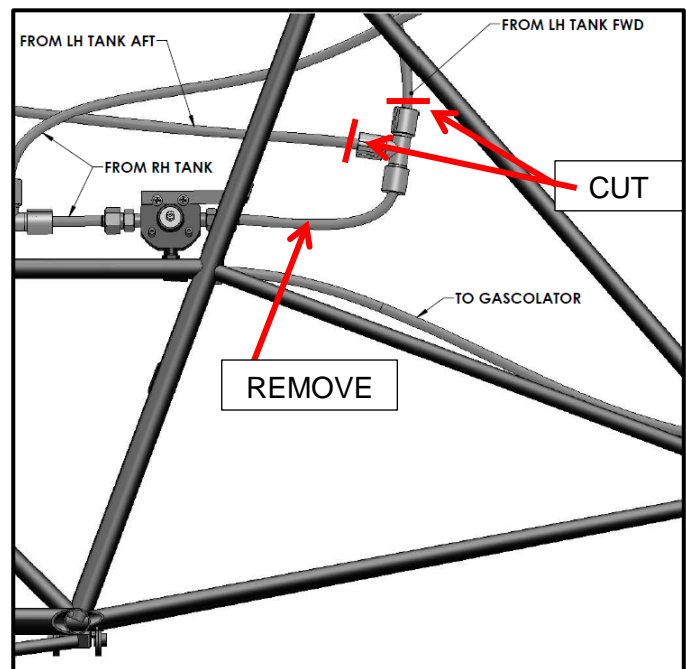

FIGURE 5B – Alternate Fuel Routing

Cub Crafters, Inc. Considers Compliance Mandatory

21. Reroute the LH aft fuel line through the upper 1" hole in the boot cowl spacer (see Figure 11) just below the upper stringer. Temporarily secure with masking tape (see Figure 6). Ensure that the fuel line follows a smooth and straight path from just forward of the lower rear window corner through the boot cowl spacer. The line should be crossing the upper stringer near an upside down "Y" of fuselage tube where the upper stringer is affixed to the frame. Mark the location on the top and bottom flange of the upper stringer.

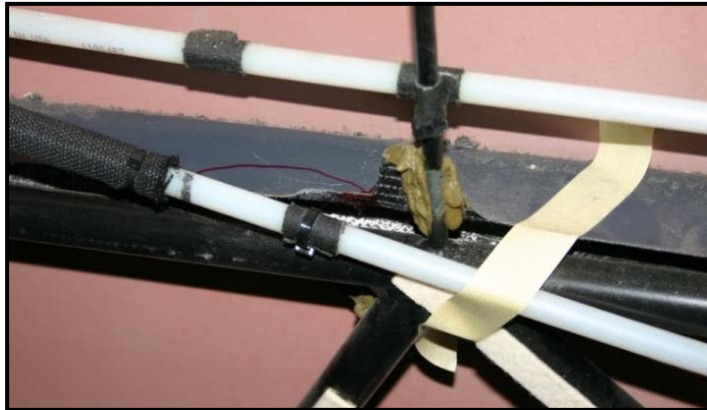

FIGURE 6 – Fuel Line Crosses Stringer

22. Remove the temporary tape and lay the LH fuel line aside and out of the way.
 23. Take care to protect the fuselage tube, fabric skin, and the wiring harness where it runs through the upper stringer.

CAUTION
Avoid nicking or grinding into structural tubes when drilling holes.

24. Using a vacuum to collect dust and chips as you go, cut or grind a notch where marked in the upper and lower flanges of the upper stringer large enough to allow the fuel line to route through the stringer and outboard of the fuselage tube. The notch will have a minimum width of about 5/8" and a length of 1-1/8". Drill one 3/16" diameter hole through the stringer near each notch. Deburr all edges and clean up any stray dust or carbon fiber chips. Install grommet strip along edge of notches. See Figure 7.

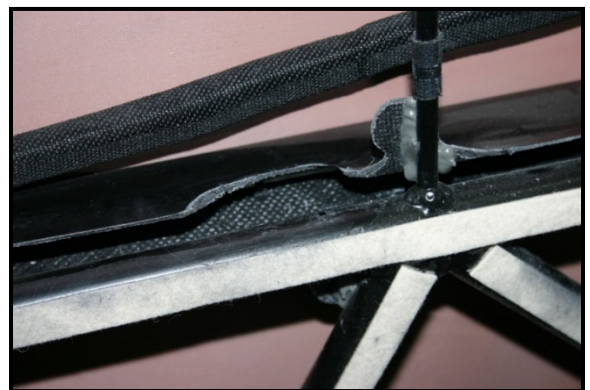

FIGURE 7 – Deburred Notch

25. Inspect the fuselage tube and wiring around the area to ensure they have not been damaged.

Cub Crafters, Inc. Considers Compliance Mandatory

- 26. Drill and deburr a 3/16" hole in bottom flange of window trim (vacuuming all chips and dust). Take care to protect fabric with smooth edged sheet of material such as metal, nylon, or thin wood. See Figure 8.
- 27. Install grommet strip onto raw edge of composite, then secure fuel line using cable ties (see Figure 9) per Appendix B of this document.

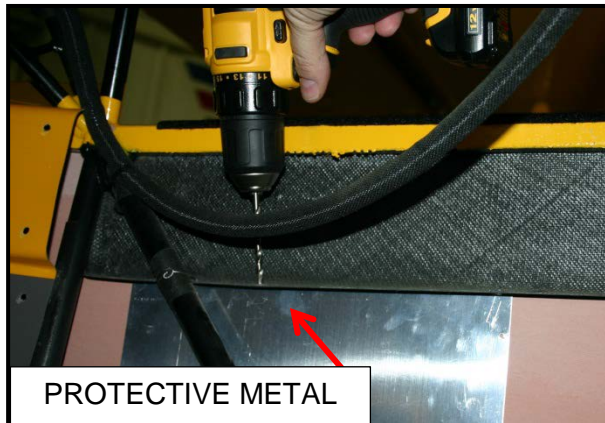

FIGURE 8 – Window Trim Drilled Hole



FIGURE 9 –Composite with Grommet Strip Installed

- 28. Pull back round-it protective wrap from LH aft fuel line to a point above notches in stringer. Slip the 9" section of nylon tubing over the fuel line and position it so that it protects the line from the stringer notches (Figure 10). Replace or add chafe protection wrap and secure per Appendix B, ensuring that it stops approximately 1" away from boot cowl spacer. Route protected fuel line through notches along path previously laid out.



FIGURE 10 - 1/2" Nylon Tubing

Cub Crafters, Inc. Considers Compliance Mandatory

FOR SERIAL NUMBERS CC11-00001 – CC11-00011, PROCEED TO STEP 29

FOR SERIAL NUMBERS CC11-00012 AND ON, SKIP TO STEP 38

- 29.** Measure down 4.2" from the fuselage tube above the new fuel line location and drill a 3/4" Ø hole in the boot cowl spacer. Space the hole laterally between the tube and former (see Figure 11). Deburr the hole and remove any metal shavings.

CAUTION

Avoid nicking or grinding into structural tubes when drilling holes.

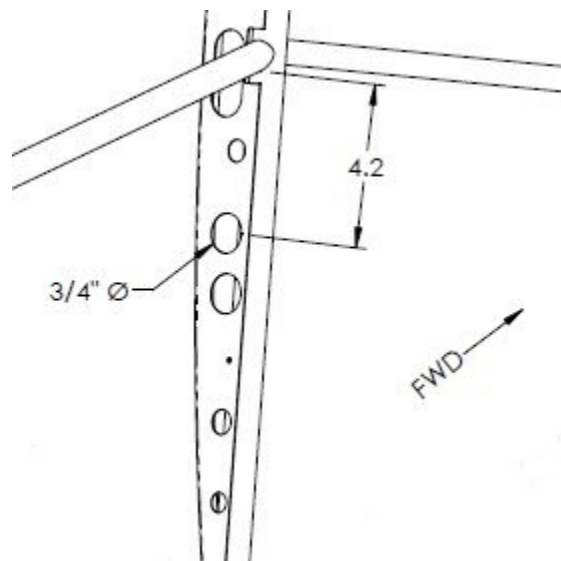

FIGURE 11 – Hole in Boot Cowl Spacer

- 30.** Install a rubber grommet into the hole. It may be necessary to trim approximately 3/16" off one side for proper fit.
- 31.** Gently push the LH aft fuel line through the grommet until it follows the straight path required.
- 32.** From underneath the aircraft, locate and remove the access panel located on the LH side of the bottom boot cowl.
- 33.** Drill out the three rivets on the forward face of the boot cowl.
- 34.** Drill out the two rivets below the access hole.
- 35.** Cut out access hole. Ensure proper fit of SC53107-001, Boot Cowl Hatch. Reference Figures 12A and 12B. Radius the upper, aft corner, and deburr all edges.
- 36.** Remove excess material below access panel (as shown in Figure 23).
- 37.** Drill holes as required for hardware installation, see Figure 12B.

Cub Crafters, Inc. Considers Compliance Mandatory

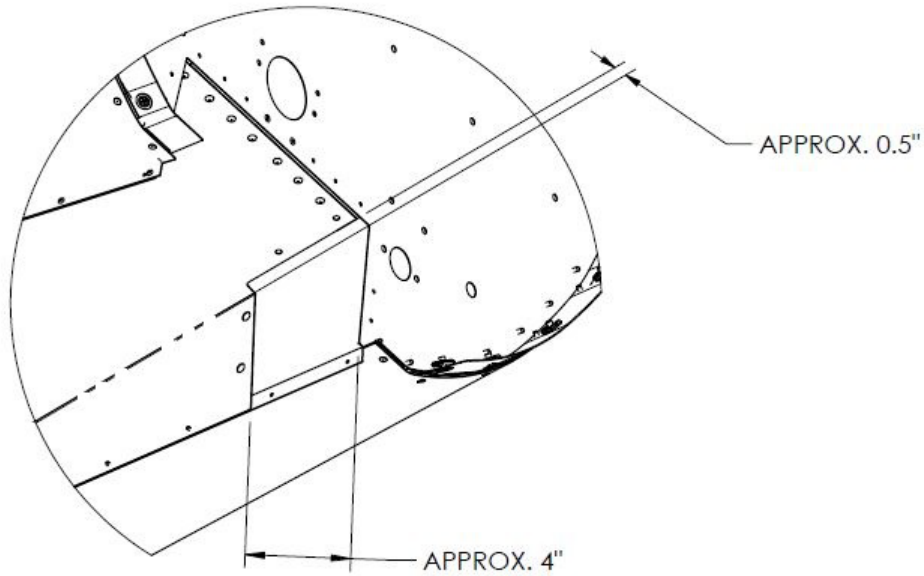

FIGURE 12A – Access Hole

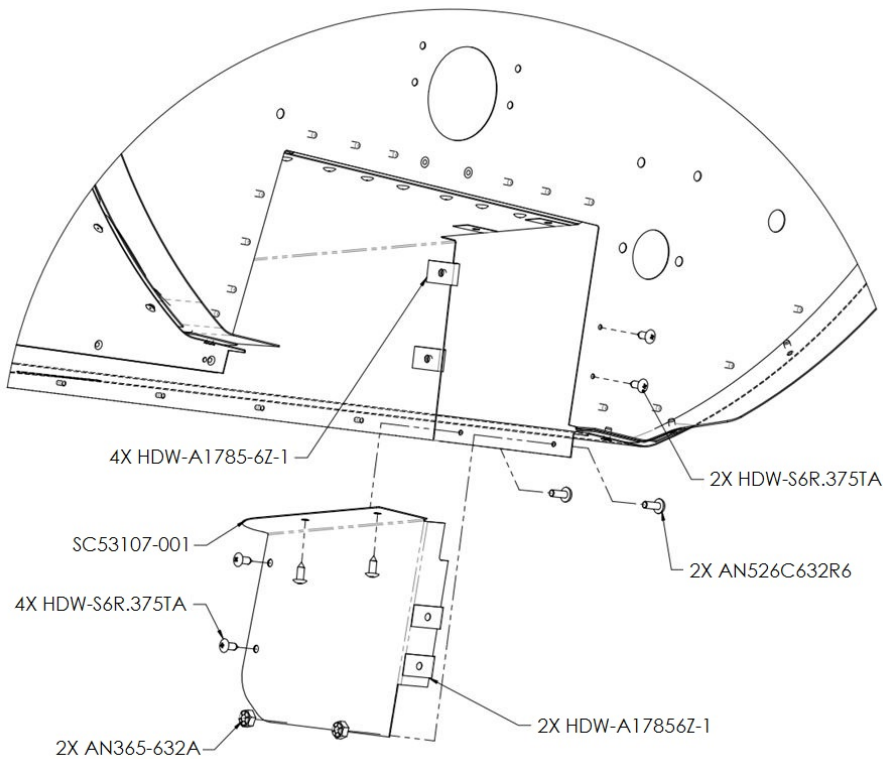

FIGURE 12B – Access Cover Installation

Cub Crafters, Inc. Considers Compliance Mandatory

38. Install the rubber grommet into upper 1" hole of boot cowl spacer (Figure 13). It may be necessary to trim approximately 3/16" off one side for proper fit.

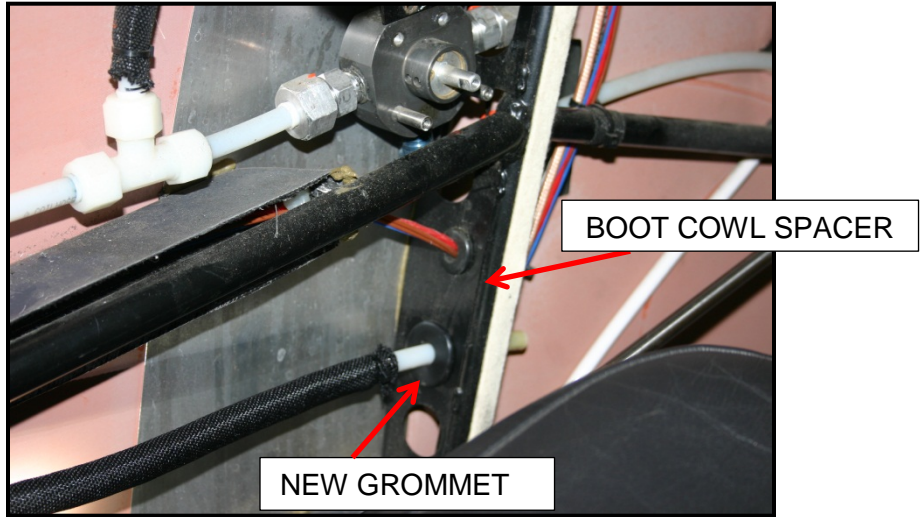

FIGURE 13 - Grommet Installation

39. Gently push the LH aft fuel line through the grommet until it follows the same straight path described previously.
40. Secure the fuel line to the stringer notches using cable ties per Appendix C of this document, then skip to step 44.

ALTERNATE FUEL LINE CONFIGURATION ONLY

41. Install a new union tee where the old one was removed. Connect an 18" section of poly-flo tubing (trim to fit as required) to fuel selector using retained compression fittings per Appendix C of this document. Reinstall chafe protection wrap per Appendix B. Trim to fit as required.
42. From the lower arm of the union tee, connect another 18" section of poly-flo tubing and route to the trunk of the lower union tee (see Figure 14), trim tubing to fit as required.
43. Skip to step 50 below.

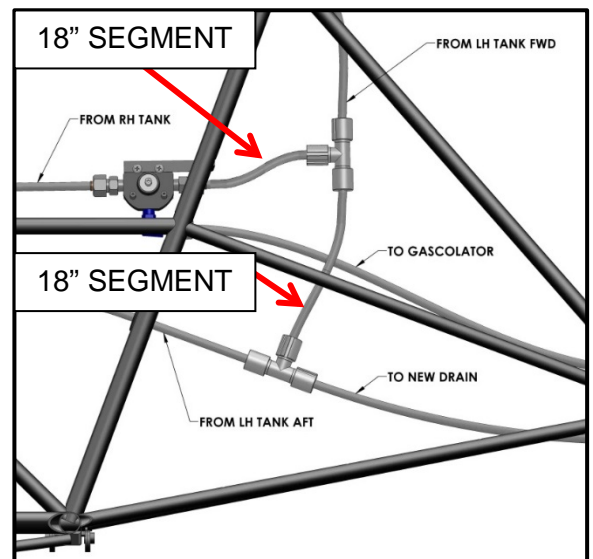

FIGURE 14 – New Alternate Fuel Line Routing

Cub Crafters, Inc. Considers Compliance Mandatory

- 44. Cut one 4" and one 10" section of new fuel line (SP60009-003). Trim the 10" section down as required.
- 45. Connect (2) union tees (SP60003-001) to either end of the 10" section of tube per Appendix A of this document. Connect the 4" section of tube to one arm of upper tee. Install round-it protective wrap on each section per Appendix B of this document. See Figure 15.

NOTE

It may be necessary to cut the cable tie that secures the LH forward fuel line to the fuselage in order to achieve a smooth transition between fuel lines.

- 46. Remove cable tie, pull chafe protection wrap away from LH forward fuel line.
- 47. Connect the LH forward fuel line to the other side of the upper tee per Appendix A and 4" section to fuel selector using retained compression fittings per Appendix C of this document. Reinstall chafe protection wrap per Appendix B.
- 48. Connect the tee opposite the 10" section of tube to the LH aft fuel line where it has passed through the grommet and boot cowl spacer. See Figures 15 and 16.



FIGURE 15 – Fuel Line with Round-It Protective Wrap Installed

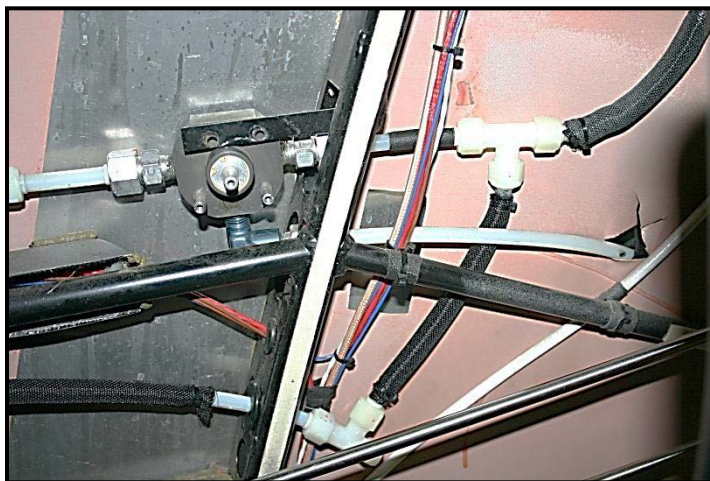

FIGURE 16 – Nylon Tubing Installation

- 49. Remove access panel at front of boot cowl, retaining all fasteners.
- 50. Remove engine cowl, retaining all fasteners (Ref. AMM 6.3.13)

Cub Crafters, Inc. Considers Compliance Mandatory

51. If your aircraft has exit fairings (Ref. Figure 17) installed, it may be necessary to remove them (retaining all fasteners) before continuing. Verify that locating the new drain 3-3/4" aft of the firewall will safely clear the exit fairings. If not, shift the pattern aft as needed.
52. Apply vinyl drill jig flat at bottom left side of boot cowl with large center hole 3-3/4" aft of firewall, centered between two bends of boot cowl sheet metal and parallel to exhaust tunnel edge (see Figure 18). Secure in place using masking tape.
53. Lightly center-punch all five holes shown on drill jig. Carefully drill an 11/16" diameter hole through bottom skin of boot cowl where indicated on drill jig.
54. Drill four 5/32" diameter screw clearance holes through the bottom skin of boot cowl where indicated on drill jig.

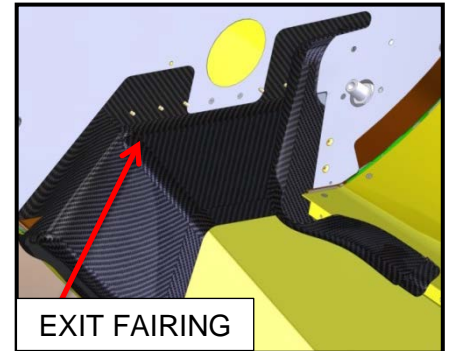

FIGURE 17 – Exit Fairing Location
(Engine compartment as viewed from aircraft underside, firewall shown in gray)

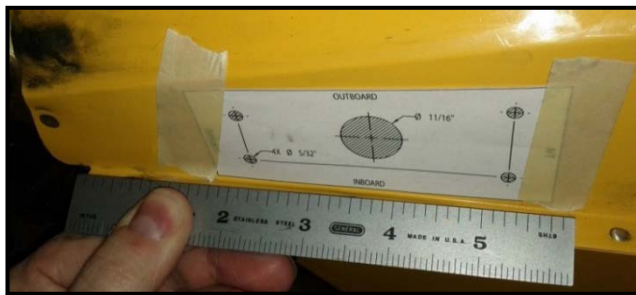

FIGURE 18 – Drill Jig Placement



FIGURE 19 – Drilled Hole Locations

55. Remove and discard vinyl drill jig (Figure 19). Deburr and clean edges of all 5 drilled holes, taking care to remove all drill chips and debris from inside boot cowl.
56. Install round-it protective wrap on remaining piece of new fuel line per Appendix B of this document, but only secure to nylon at one end. Route this end down along left inside wall of cabin and under floor just behind the firewall. This will be the sump section of fuel drain line.
57. Reach through access opening and gently pull fuel line through (Figure 20).



FIGURE 20 – Access Panel at Boot Cowl Showing Fuel Line Routing

Cub Crafters, Inc. Considers Compliance Mandatory

- 58. Connect a 1-3/4" piece of nylon tube to SC60110-001 per Appendix C of this document. Connect (1) union elbow to the other end of 1-3/4" tube per Appendix A at an angle roughly 45 degrees aft and outboard (Figure 21).
- 59. Connect fuel drain weldment/elbow assembly to fuel drain line per Appendix A (Figure 22).
- 60. Carefully push fuel drain weldment and line through access cover and align to holes.
- 61. Fasten in place using four screws as shown in Figure 23.



FIGURE 21 – Elbow Orientation
(Note the parts flare aft)



FIGURE 22 – Elbow Assembly as Installed



FIGURE 23 – Truss Head Screws as Installed

Cub Crafters, Inc. Considers Compliance Mandatory

62. Trim the forward fuel drain line to length and make the final connection to the tee forward of the boot cowl spacer, making a continual downhill slope from the lower rear window corner to fuel drain weldment. Figure 24 details LH forward section of new fuel and drain line routing. Secure round-it protective wrap on upper end of sump line per Appendix B.

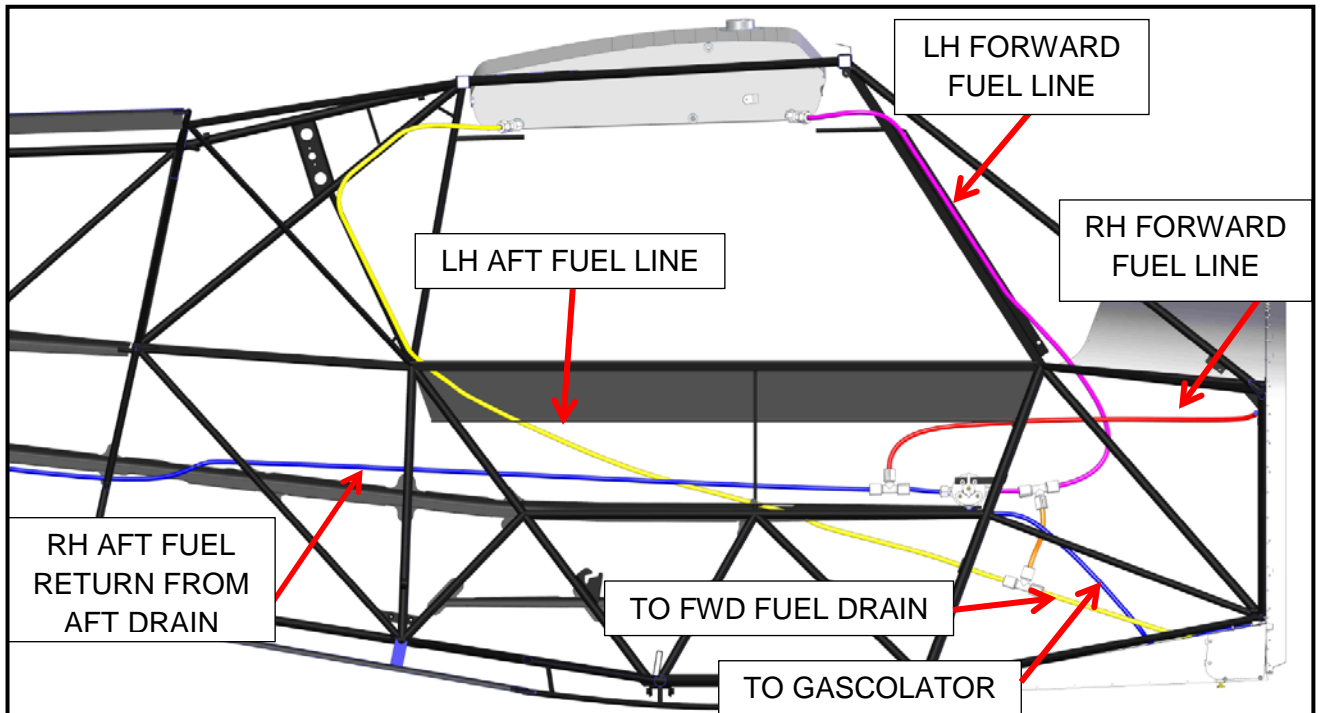

FIGURE 24 – New Fuel Line Routing

63. It may be necessary to separate the new sump section of fuel line from the starter cable. If so, protect both with electrical friction tape and/or round-it protective wrap per Appendix B and create a short standoff using two cable ties and a short section of plastic tube (Figure 25).

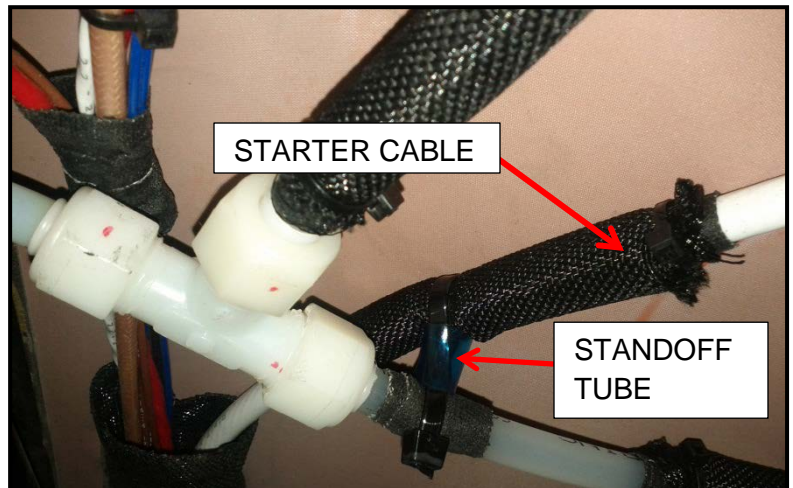

FIGURE 25 – Standoff Tube Installation (If Required)

Cub Crafters, Inc. Considers Compliance Mandatory

- 64. Some aircraft will have fabric extending forward of the boot cowl spacer (shown in Figure 26). If so, it will be necessary to cut a small slit in that section of fabric to allow the new drain line to pass well clear of the cabin floor edge.
- 65. Secure to interior surface of boot cowl with a generous bead of clear silicone sealant. Allow silicone to set per manufacturer's instruction.

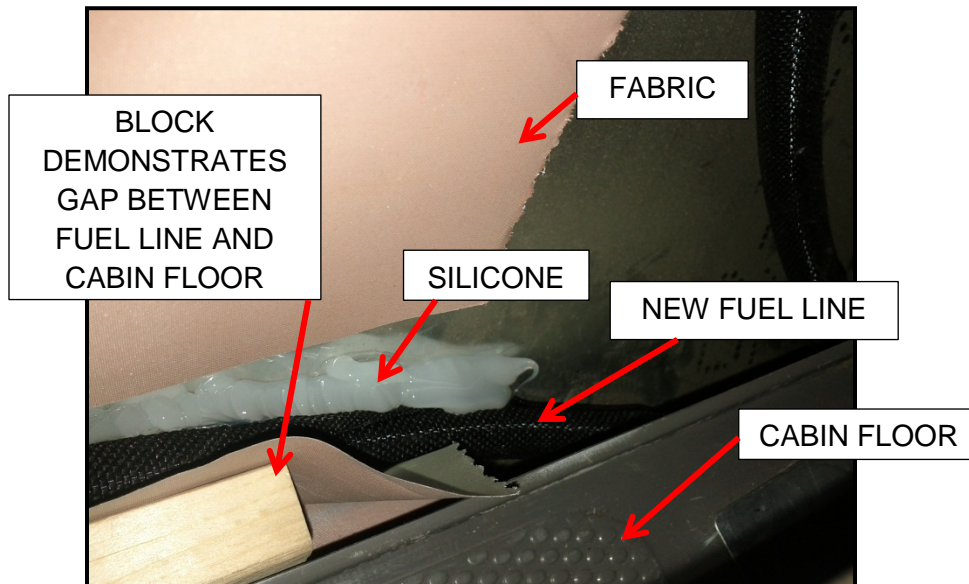

FIGURE 26 – Silicone Sealant

- 66. Install the drain assembly using a small amount of EZ-TURN fuel lube and standard practices (see Figure 27).
- 67. At every location where fuel line crosses fuselage tube, apply two full wraps of friction tape around tube, and secure chafe wrapped fuel line to fuselage tube with cable ties per Appendix B of this document.
- 68. Add 2 gallons of fuel to LH tank, place fuel selector in “LEFT” position and check system for any leaks, ensuring that there is positive flow at the new forward fuel drain and the gascolator.



FIGURE 27 – Fuel Drain Installation

- 69. Add 2 gallons of fuel to RH fuel tank, place fuel selector in “RIGHT” position and check entire system for any leaks, ensuring that there is positive flow at the rear fuel drain.
- 70. Clean off previous red silicone gasket bead from boot cowl access panel and replace with fresh bead of 26C RTV High Temp. red silicone. Allow to set per the manufacturer's specification.
- 71. Reinstall access panel at front of boot cowl using retained fasteners.

Cub Crafters, Inc. Considers Compliance Mandatory

- 72. If applicable, reinstall exit fairings using retained fasteners.
- 73. Reinstall cowling using retained fasteners. (Ref. AMM 6.3.13)
- 74. To remove double-sided tape from fuselage: Install a drill bit (approximately 1/8" bit) into a cordless drill. Hold the drill perpendicular and turn slowly to catch and remove the tape (Figure 28). A pinstripe remover eraser wheel, available from auto paint supply store may also be used.
- 75. Clean surfaces of window frame using isopropyl alcohol. Let dry. Apply adhesive promoter with an acid brush in places hook and loop tape will be installed and let it dry slightly until tacky.
- 76. Apply adhesive loop tape to window edge where tape was removed; centering the tape on the surface. Apply adhesive hook tape to underside of interior panel flange; centering the tape on the surface.
- 77. Clean fuselage tube under joint of two LH interior panels and mating faces of each panel using isopropyl alcohol. Let dry.
- 78. Apply 3M black acrylic foam tape to sections of fuselage tube where previously applied to secure interior panels and joining edge of one section of interior panel. LEAVE RED BACKING ON TOP OF TAPE UNTIL PANEL IS IN PLACE.
- 79. Carefully maneuver interior panel section into aircraft.
- 80. Reinstall throttle cable assembly. (Ref. AMM 6.3.11)
- 81. Locate panel in original position, lining up the edge of the panel with the fuselage.
- 82. Remove temporary screws on fuel selector body. Reinstall fuel selector assembly. (Ref. 6.3.15)
- 83. Remove red plastic backing and press down firmly along full length of two edges of adhesion.
- 84. Reinstall nylon snap rivets around perimeter of interior panel replacing any that have been damaged.
- 85. If applicable, reinstall rudder cable to LH rudder pedal.



FIGURE 28 - Tape Removal from Fuselage

Cub Crafters, Inc. Considers Compliance Mandatory

86. Install fuel drain placards above fuel drain locations shown in Figure 29 below. Ensure surfaces are free of any grease or dirt and are dry prior to installation.

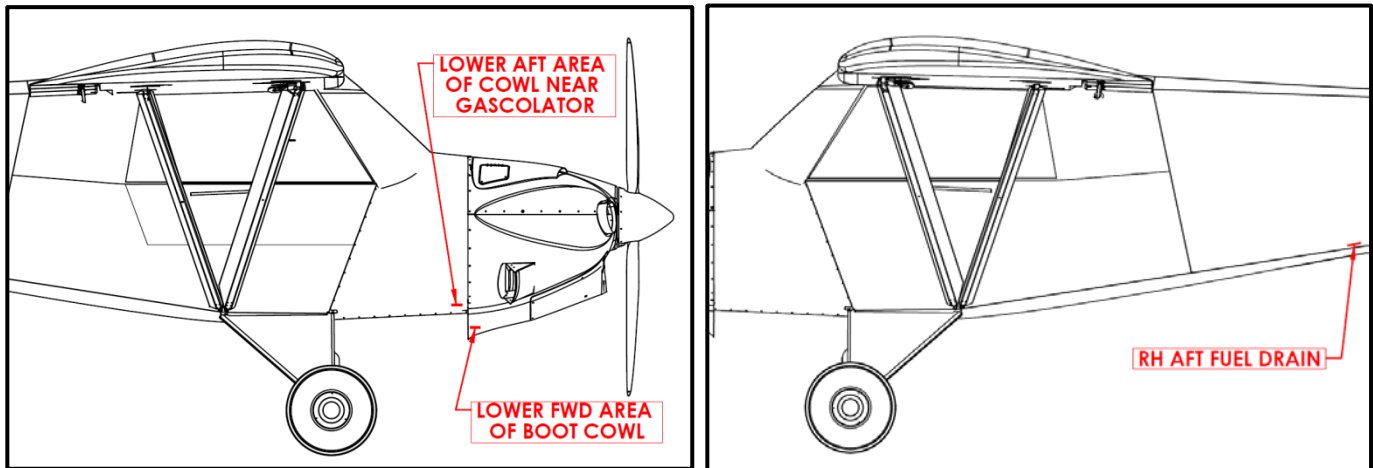

FIGURE 29 – Placard Placement

87. Make logbook entry stating SB00029 Part B has been complied with.

88. The parts kit weighs 0.7 lbs. and is installed near the center of gravity. Therefore, the effect on weight and balance is negligible.

FINAL INSPECTION:

1. Verify that throttle operates freely with full travel and hits both Idle stop and wide open stop.
2. Place fuel selector in “OFF” position and verify that no fuel drains from gascolator.
3. Place fuel selector in “LEFT” position and verify positive flow from gascolator.
4. Place fuel selector in “RIGHT” position and verify positive flow from gascolator.
5. Place fuel selector in “BOTH” position and verify positive flow from gascolator.
6. Perform engine run-up per the Pilot’s Operating Handbook.

If you are no longer in possession of this aircraft, please forward this information to the present owner/operator and notify Cub Crafters, Inc. Contact the customer service department at:

Cub Crafters, Inc.
 1918 S. 16th Avenue
 Yakima, WA 98903.
 1-877-484-7865 or 1-509-248-9491
support@cubcrafters.com

Please include the aircraft registration number, serial number, current name, and address of the owner and/or operator.

Cub Crafters, Inc. Considers Compliance Mandatory

Appendix A: Plastic Compression Fitting Assembly

Figure 30 below shows the parts needed for each fitting in the order that they need to be assembled.

1. Assembly begins by placing the nut onto the tubing. Then the small reinforcement insert is placed into the end of the tube. The tube is then slid into the fitting until it “bottoms out”. This “bottoming out” will be obvious. There is no practical way to push the tube too far but you can fail to fully insert it. The last step is to tighten the nut using your fingers. Your goal is to turn the nut until the first sign of friction is felt between fitting and nut. Mark the fitting and nut with a maker for reference. See Figure 31.
2. The dots indicate the first-friction position. The nut will be tightened later 2.25 turns past this point.
3. Starting from the first friction position set previously, turn the compression nut 2.25 turns with an open-end wrench. Use the dots you applied previously to assist in counting the number of turns. See Figure 32.
4. Once tight, apply a spot of Loctite primer and then a spot of Loctite plastics bonding system (Loctite P/N 681925) to each fitting compression nut (Figure 33). Allow glue to cure per product specifications.



FIGURE 30 –ASSEMBLY ORDER

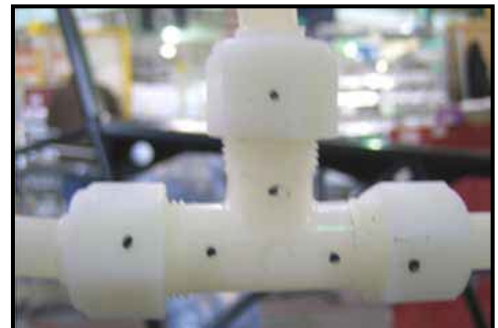

FIGURE 31 – Fitting Reference



FIGURE 32 – Fitting Torque



FIGURE 33 – Loctite Application

Cub Crafters, Inc. Considers Compliance Mandatory

Appendix B: Chafe Protection and Prevention

1. Round-It Protective Wrap Installation

Apply 1 to 2 wraps of electrical friction tape approximately 1"-2" from end of nylon tube. Open the round-it protective wrap and wrap it around the nylon tube, aligning one end over the middle of the electrical friction tape. Secure the end of the round-it protective wrap around the friction tape using one cable tie. This will prevent the chafe wrap from slipping along the fuel line. See Figure 34 below.

2. Cable Tie Installation

When securing chafe protected tube to a fuselage tube or composite component, use two cable ties to create a short chain.

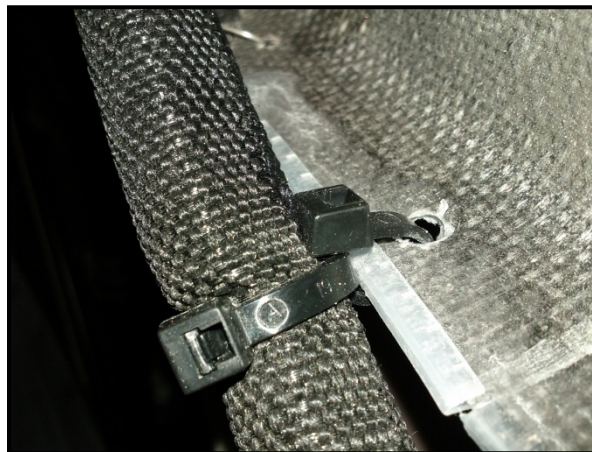
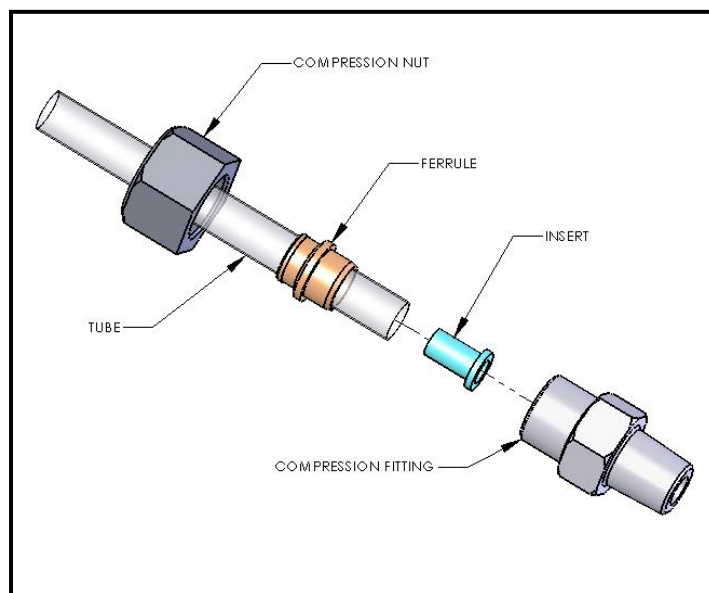

FIGURE 34 – Secure Round-It Protective Wrap using Cable Tie Chain

Cub Crafters, Inc. Considers Compliance Mandatory**Appendix C: Metal Compression Fitting Assembly Procedure**

Installation of metal compression fittings involves a pre-installation check before tube fittings can be installed. Prior to installing the fittings, check to make sure there are no dents, nicks, and scratches, that the assembly contains the correct components, that there is a proper fit, and that the components are clean. If threads on the fitting are badly nicked or galled, replace the fitting.

1. Inspect threads ensuring that they are free of dirt, burrs and excessive nicks.

**FIGURE 35 – Compression Fitting Assembly**

2. Insert tube into compression nut as shown in Figure 35.
3. Place insert into tube ensuring that tube end is touching insert shoulder.
4. Tighten the nut finger tight until friction is felt. Tighten the nut 2-1/2 turns.