



SAFETY ALERT SA0002

Cub Crafters, Inc. Considers Compliance Mandatory 10/02/06

EFFECTIVE DATE: This Safety Alert is effective October 2, 2006

SUBJECT: Engine Mount and Jury Strut Modification

MODELS AFFECTED: CC11-100 S/N CC11-00001 thru CC11-00003.

COMPLIANCE TIME: Prior to Next Flight

PURPOSE: Modify Engine Mount and Jury Strut Installation

PARTS LIST:

<u>PART DESCRIPTION</u>	<u>QUANTITY</u>
ATTENUATOR, VISCO-ELASTOMERIC	4
GROMMET	4

INSTRUCTIONS:

Engine Mount Modification

**NOTE:
READ AND UNDERSTAND ALL INSTRUCTIONS BEFORE BEGINNING WORK.**

1. Remove upper and lower engine cowl per CC11-100 Maintenance Manual Section 6.3.14.
2. Working on one engine isolator mount at a time:
 - a. Remove nut. Bolt may also be removed, if necessary.
 - b. Remove forward isolator mount (See Figure 1).
 - c. Remove spacer (See Figure 2).
 - d. Remove rubber hose from spacer (See Figure 2).
 - e. Install supplied visco-elastomeric attenuator over spacer.
 - f. Install spacer in original position.

**NOTE:
APPLY FORCE AS NECESSARY TO POSITION ENGINE AND ALLOW
SPACER TO ENTER ENGINE MOUNT BORE.**

- g. Install forward isolator mount.
- h. Install bolt, if removed, and nut. Replace the nut if an AN363-720 self-locking metal stop nut was originally installed.
3. Complete Step 2 on remaining engine isolator mounts.
4. Torque all nuts to 175-190 in-lbs.
5. Install cotter pin AN380-3-3 in each nut, if necessary.
6. Install upper and lower engine cowl.

Cub Crafters, Inc. Considers Compliance Mandatory 10/02/06

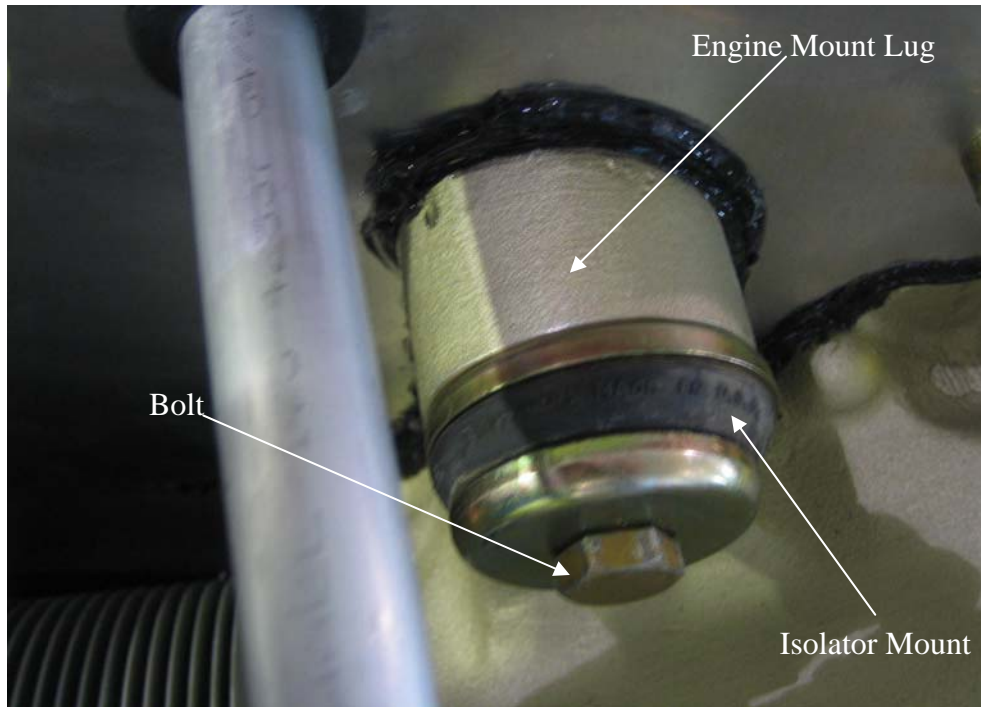

Figure 1

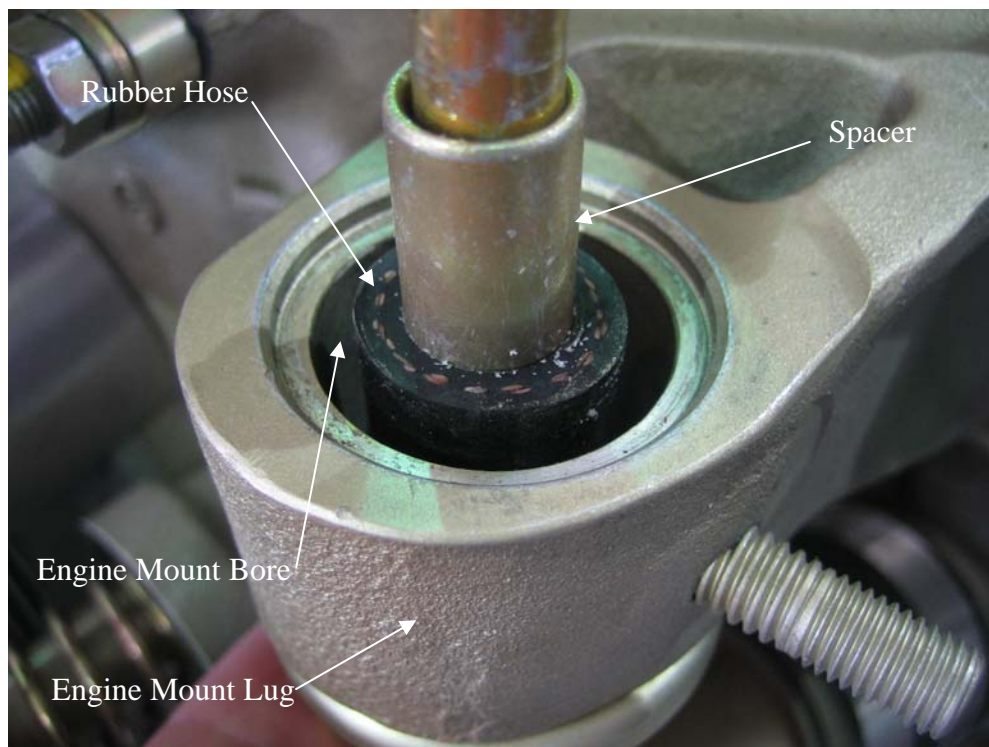

Figure 2

Cub Crafters, Inc. Considers Compliance Mandatory 10/02/06

Jury Strut Modification

NOTE:

Read and understand all instructions before beginning work.

1. Disconnect upper and lower jury strut attachments.
2. Inspect upper and lower jury strut fitting for cracks. Replace, if cracked.
3. Open hole in lower jury strut fitting (P/N SC37204-001) to .250" \pm .003".
4. Install grommet in lower jury strut fitting (P/N SC37204-001). See Figure 3.
5. Install jury strut as noted (See Figure 3 and Figure 4) with hardware supplied.
6. Tighten nuts finger tight, advance to next castellation, and install cotter pin AN380-2-2.
7. Repeat steps 1-6 for opposite side.
8. Make a logbook entry showing that you have complied with Safety Alert SA0002.

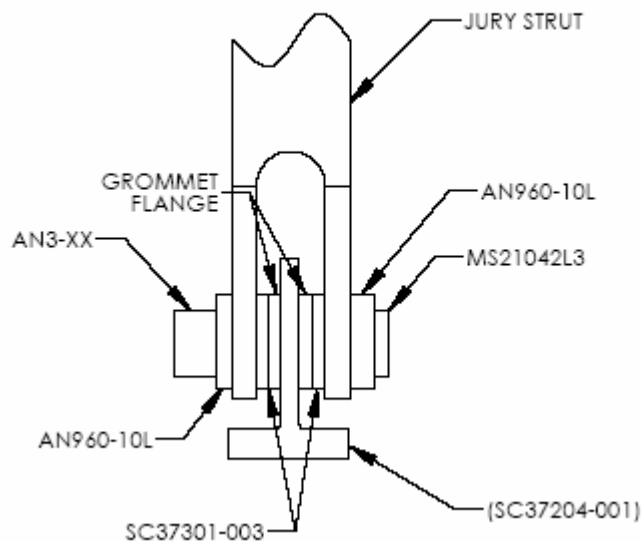

Figure 3 - Lower Jury Strut Attachment Installation

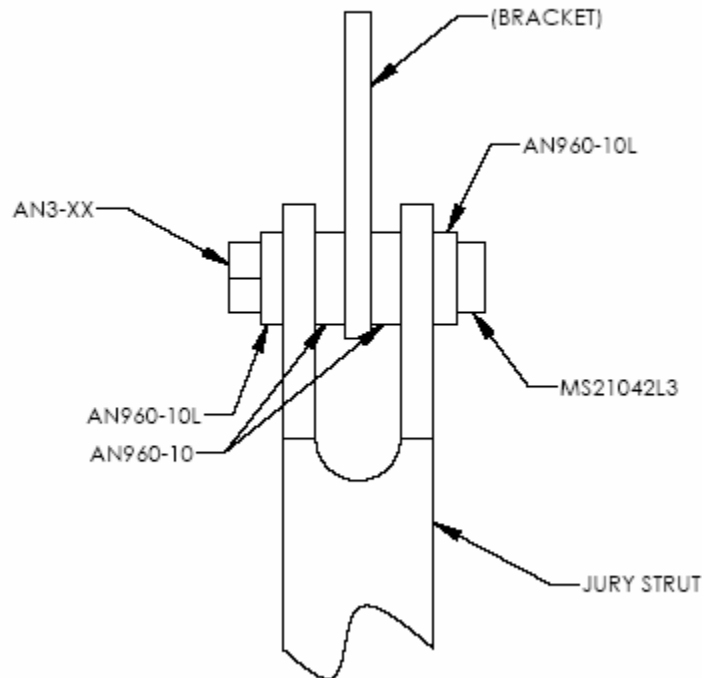

Figure 4 - Upper Jury Strut Attachment Installation

NOTE:

If you are no longer in possession of this aircraft, please forward this information to the present owner/operator. Notify Cub Crafters, Inc. of the current owner's address. Contact the customer service department at:

Cub Crafters, Inc.
1918 S. 16th Avenue
Yakima, WA 98903

Phone: (509) 248-9491

or e-mail Earl Barnes at earlb@cubcrafters.com

Please include the aircraft registration number, serial number, and the name and address of the current owner/operator.