

Cub Crafters, Inc. Considers Compliance Mandatory

- EFFECTIVE DATE:** This NOTIFICATION is effective June 29, 2007
- SUBJECT:** Flap Handle Fatigue Cracks
- MODELS AFFECTED:** CC11-100 S/N CC11-00002 thru CC11-00050 that have the original part as shown in Figure 2 below.
- COMPLIANCE TIME:** Every 100 hours or during annual inspection whichever comes first.
- PURPOSE:** Flap Handle Fatigue Crack Inspection
- INSTRUCTIONS:**
1. Inspect flap handle in location shown in Figure 1 for cracks.
 2. If cracks are found, contact Cub Crafters Inc. for further information and instruction.
 3. For aircraft that have an upgraded flap handle, the requirement for inspection is terminated. See Figure 2 for cross-sectional views of upgraded and original parts.

NOTE

Aircraft with Flap Handle Assembly P/N SC32200-001 Rev G or later have an upgraded flap handle.

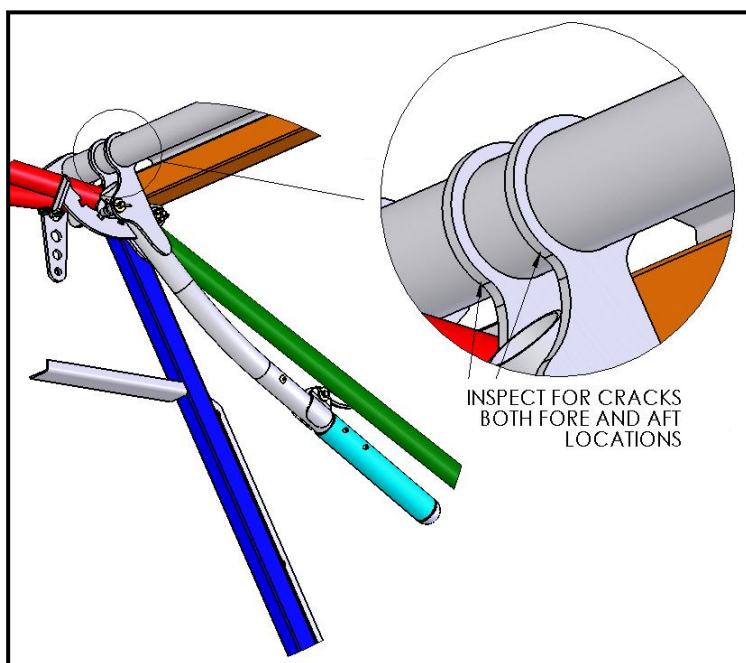

Figure 1 – Inspection Location

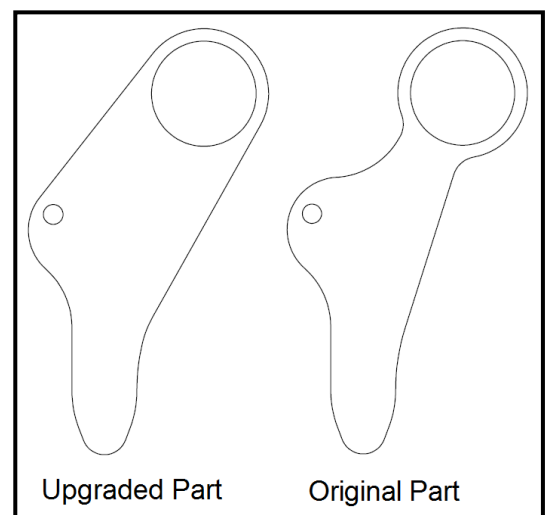

Figure 2 – Inspection Location



NOTIFICATION

NB00003

Rev B

Page 2 of 2

Cub Crafters, Inc. Considers Compliance Mandatory

4. Upon completion, make the following logbook entry stating compliance with NB00003 Rev B.

If you are no longer in possession of this aircraft, please forward this information to the present owner/operator and notify Cub Crafters, Inc. of the address of the current owner at:

1918 South 16th Avenue
Yakima, WA 98903-1212
Phone: (877) 484-7865 or (509) 248-9491
Fax: (509) 248-1421

Email: support@cubcrafters.com
Website: www.cubcrafters.com

Please include the aircraft registration number, serial number, current name, and address of the owner and/or operator.